



---

**CO-ORDINATED SCIENCES**

**0654/13**

Paper 1 Multiple Choice (Core)

**October/November 2019**

**45 minutes**

Additional Materials: Multiple Choice Answer Sheet  
Soft clean eraser  
Soft pencil (type B or HB is recommended)



---

**READ THESE INSTRUCTIONS FIRST**

Write in soft pencil.

Do not use staples, paper clips, glue or correction fluid.

Write your name, centre number and candidate number on the Answer Sheet in the spaces provided unless this has been done for you.

**DO NOT WRITE IN ANY BARCODES.**

There are **forty** questions on this paper. Answer **all** questions. For each question there are four possible answers **A, B, C** and **D**.

Choose the **one** you consider correct and record your choice in **soft pencil** on the separate Answer Sheet.

**Read the instructions on the Answer Sheet very carefully.**

Each correct answer will score one mark. A mark will not be deducted for a wrong answer.

Any rough working should be done in this booklet.

A copy of the Periodic Table is printed on page 20.

Electronic calculators may be used.

---

This document consists of **17** printed pages and **3** blank pages.

- 1 The diagram shows a germinating seed in the soil.

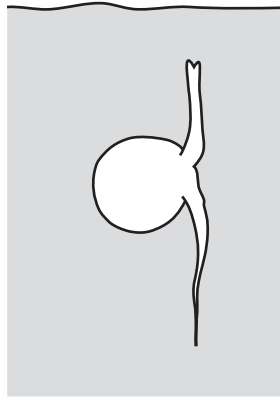

Which characteristics of living organisms is the seed demonstrating?

	characteristic	
	growth	sensitivity
<b>A</b>	✓	✓
<b>B</b>	✓	x
<b>C</b>	x	✓
<b>D</b>	x	x

- 2 The diagram shows a section through a cell.

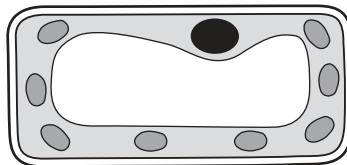

What shows that this is a plant cell?

- A** It has a cell membrane.  
**B** It has a nucleus.  
**C** It has a permanent vacuole.  
**D** It has cytoplasm.
- 3 Which result with the biuret test shows that protein is present?
- A** blue  
**B** green  
**C** orange  
**D** purple

4 Which graph shows how enzyme activity is affected by temperature?

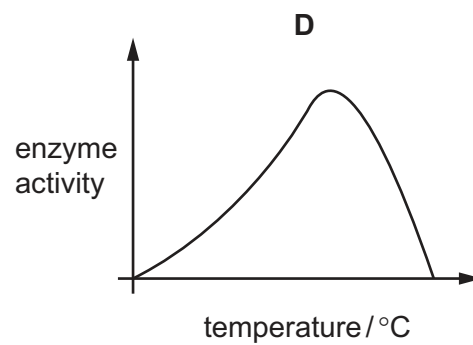
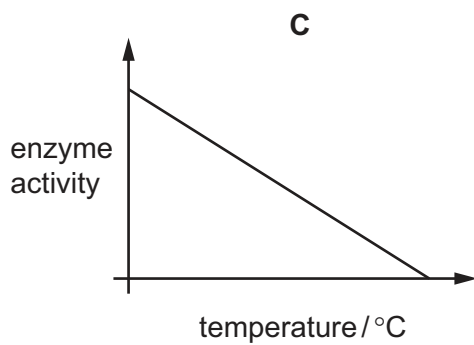
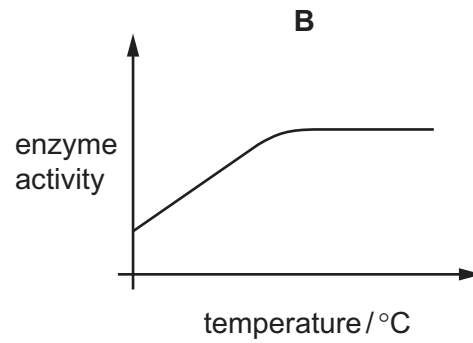
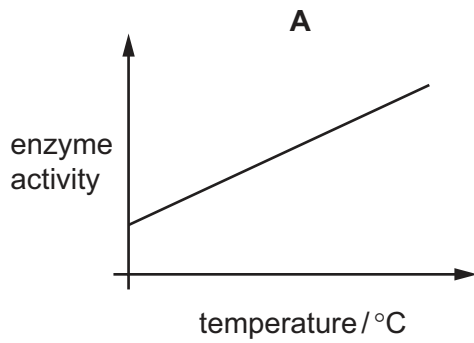

5 What is the word equation for photosynthesis?

- A** carbon dioxide + glucose → oxygen + water
- B** carbon dioxide + water → oxygen + glucose
- C** oxygen + glucose → carbon dioxide + water
- D** oxygen + water → carbon dioxide + glucose

6 Where is bile stored?

- A** gall bladder
- B** liver
- C** pancreas
- D** stomach

7 The diagrams show sections through a stem and a root.

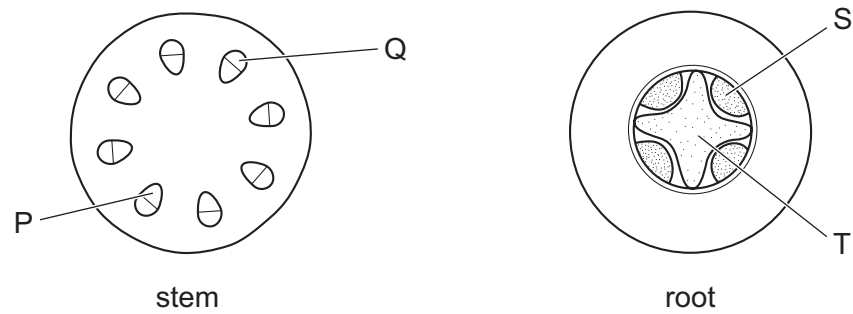

Which indicate the positions of the xylem?

- A** P and S      **B** P and T      **C** Q and S      **D** Q and T

8 Which area represents the substances produced in aerobic respiration?

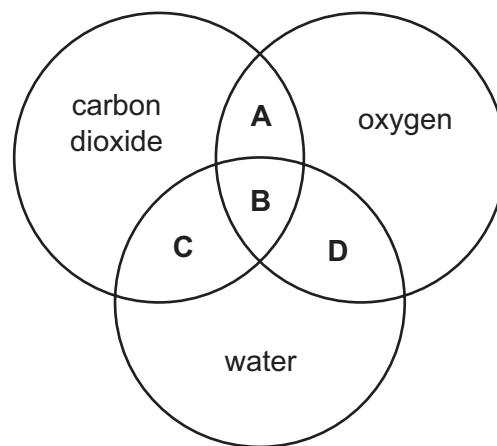

- 9 Which diagram shows the sequence of neurones in a reflex arc, and the direction of travel of the electrical signal?

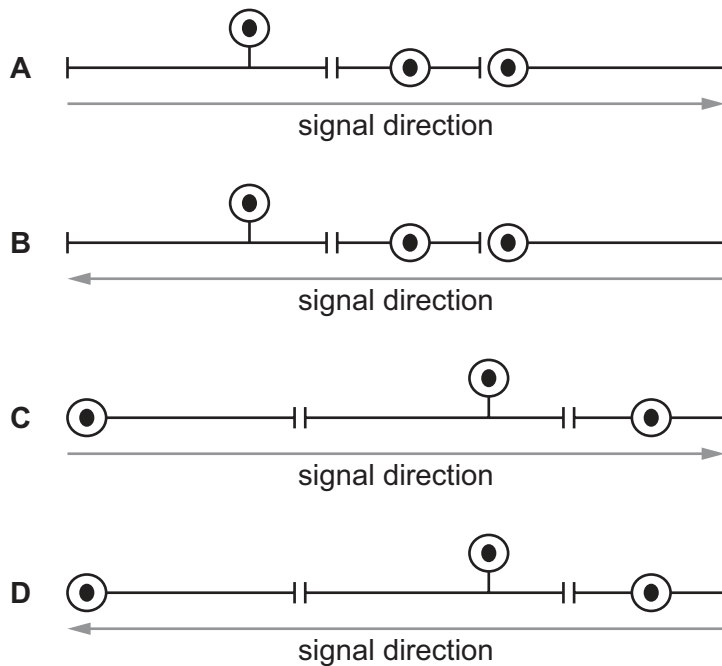

- 10 Duckweed can reproduce by producing new plants from an original 'mother plant' as shown. These plants can then separate off and produce more plants themselves.

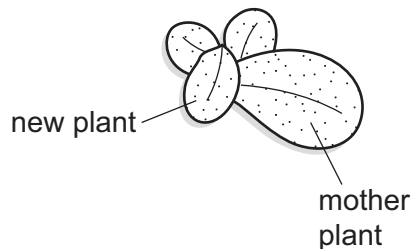

What does this demonstrate about how duckweed reproduces?

- A asexual reproduction which produces genetically different plants
- B asexual reproduction which produces genetically identical plants
- C sexual reproduction which produces genetically different plants
- D sexual reproduction which produces genetically identical plants
- 11 A pure-breeding mouse with black fur was bred with a pure-breeding mouse with white fur. All the offspring had black fur.

What are the genotypes of the two parent mice?

- A  $Bb \times bb$       B  $Bb \times Bb$       C  $BB \times bb$       D  $BB \times BB$

12 What is the principal source of energy input into a biological system?

- A consumer
- B decomposer
- C producer
- D Sun

13 The diagram shows some of the processes in the carbon cycle.

Which process is respiration?

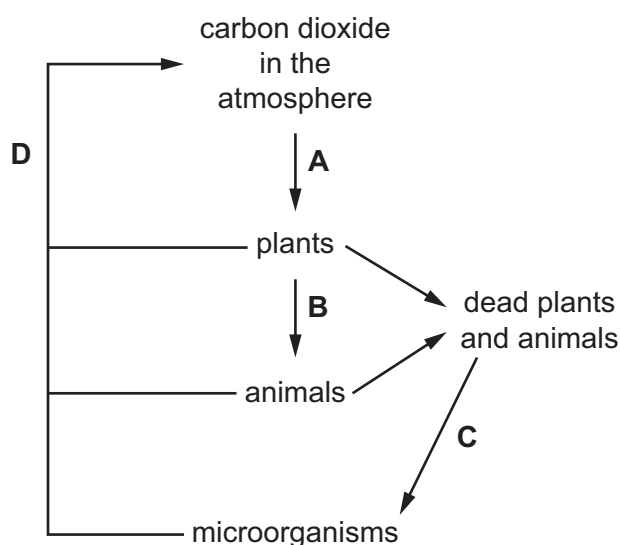

14 Which processes are chemical changes?

- 1 conversion of steam to liquid water
- 2 cracking of alkanes
- 3 fractional distillation of petroleum
- 4 thermal decomposition of calcium carbonate

- A 1 and 3
- B 1 and 4
- C 2 and 3
- D 2 and 4

15 Which row compares the nucleus and the electronic structure of two isotopes of the same element?

	nucleus	electronic structure
<b>A</b>	different	different
<b>B</b>	different	same
<b>C</b>	same	different
<b>D</b>	same	same

16 Hydrogen peroxide is a compound.

A molecule of hydrogen peroxide can be represented as shown.



key

● = oxygen

○ = hydrogen

What is the formula of hydrogen peroxide?

A HO

B H<sub>2</sub>O<sub>2</sub>

C (OH)<sub>2</sub>

D 2OH

17 The table shows the temperature of some water before and after a solid is dissolved in it.

Which change is the most exothermic?

	temperature before /°C	temperature after /°C
A	20	18
B	20	40
C	25	18
D	25	42

- 18 When  $50\text{ cm}^3$  of dilute hydrochloric acid and excess solid sodium carbonate are mixed, they react to form carbon dioxide gas.

The gas is collected in a gas syringe.

The experiment is repeated using  $25\text{ cm}^3$  of dilute hydrochloric acid.

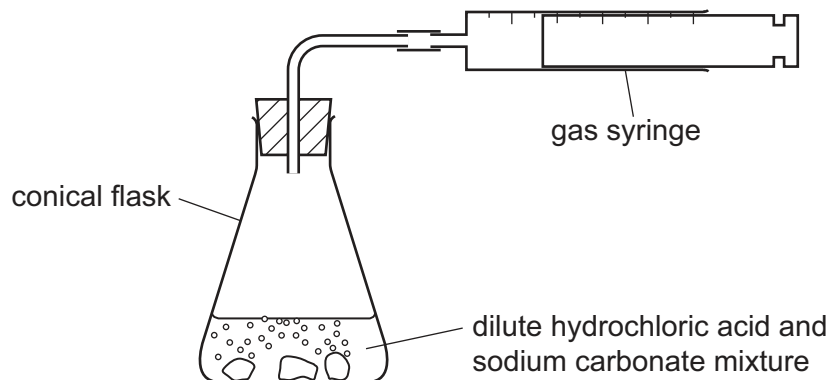

Which statement about the second experiment compared to the first experiment is correct?

- A It has the same initial rate of reaction and produces a lower volume of gas.
  - B It has the same initial rate of reaction and produces the same volume of gas.
  - C It has a slower initial rate of reaction and produces a lower volume of gas.
  - D It has a slower initial rate of reaction and produces the same volume of gas.
- 19 The colours in an ink can be separated by chromatography.

Which diagram shows the correct way to set up the apparatus?

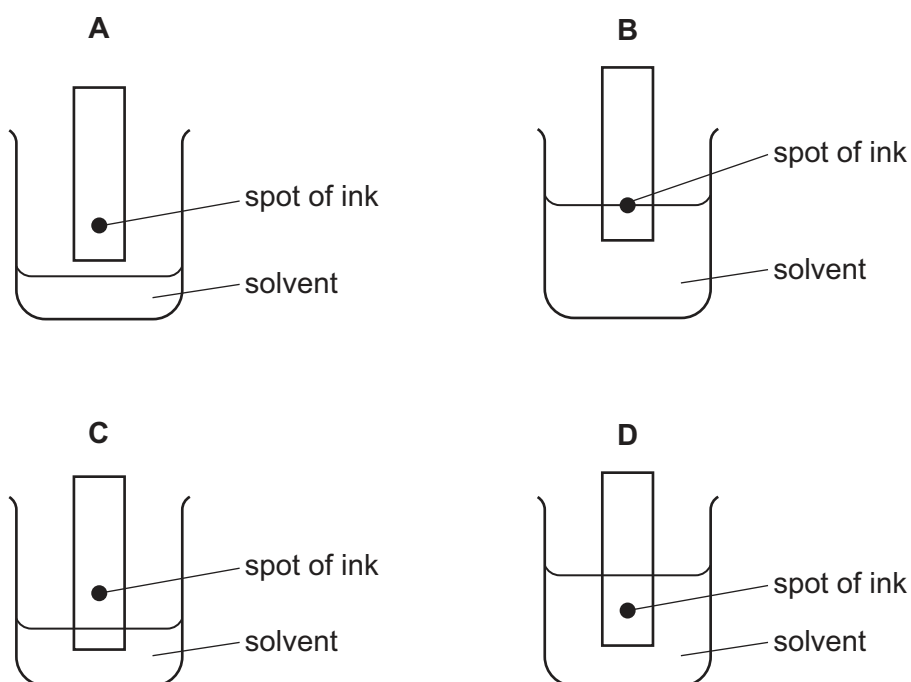



20 Which statement about the Periodic Table is correct?

- A Elements are listed in order of neutron number.
- B Elements are listed in order of nucleon number.
- C Elements are listed in order of proton number.
- D Elements are listed in order of relative atomic mass.

21 The halogens are elements in Group VII of the Periodic Table.

They are .....1..... non-metals.

They become .....2..... in colour down the group.

Which words complete gaps 1 and 2?

	1	2
A	diatomic	darker
B	diatomic	lighter
C	monatomic	darker
D	monatomic	lighter

22 Which statement describes **all** metals?

- A They break when hit with a hammer.
- B They conduct electricity.
- C They dissolve in water.
- D They have high densities.

23 When substance X is added to blue cobalt(II) chloride paper, the paper turns pink.

What is X?

- A ammonia
- B an acid
- C chlorine gas
- D water

24 Which processes produce carbon dioxide?

- 1 acid reacting with a metal
- 2 respiration
- 3 combustion of ethanol
- 4 acid reacting with a metal oxide

A 1 and 2      B 1 and 4      C 2 and 3      D 3 and 4

25 Which row describes lime and the solubility of limestone in water?

	lime	limestone
<b>A</b>	acidic oxide	insoluble
<b>B</b>	acidic oxide	soluble
<b>C</b>	basic oxide	insoluble
<b>D</b>	basic oxide	soluble

26 Which structure represents ethanol?

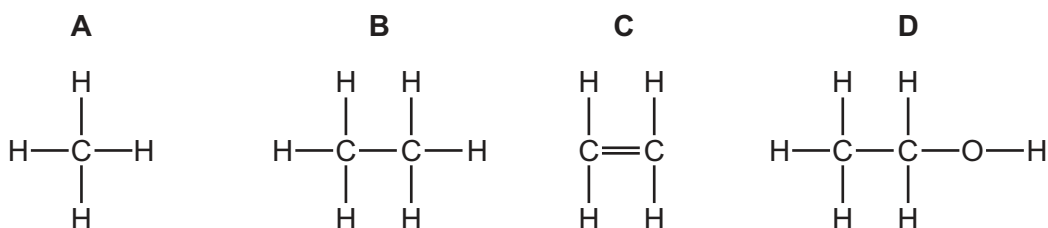

27 Which type of reaction is represented by the equation?

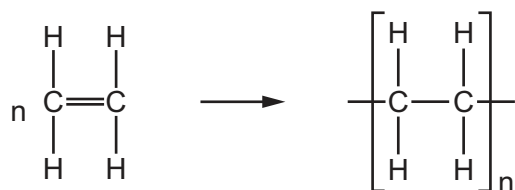

- A** addition polymerisation
- B** cracking
- C** fermentation
- D** reduction

28 A stone is lowered into a measuring cylinder containing water.

The diagrams show the readings on the measuring cylinder with and without the stone.

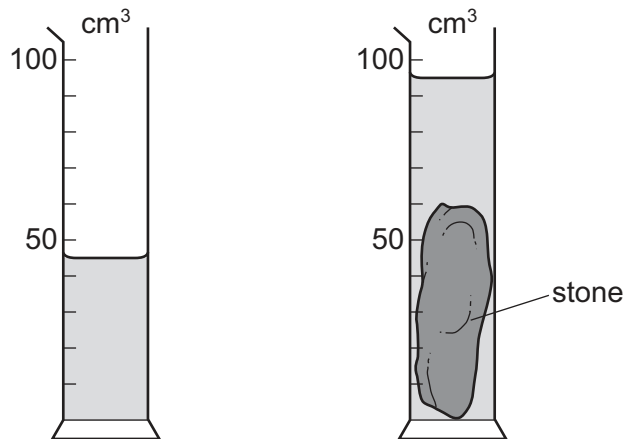

What is the volume of the stone?

- A** 40 cm<sup>3</sup>      **B** 50 cm<sup>3</sup>      **C** 60 cm<sup>3</sup>      **D** 95 cm<sup>3</sup>

29 There is no resultant force acting on a body.

Which statement is correct?

- A** The body is either at rest or moving at constant speed in a straight line.  
**B** The body must be at rest.  
**C** The body is gaining speed.  
**D** The body is losing speed.

30 Four cars are driven the same distance along a straight, horizontal road.

The table shows the work done by the engine in each car and the time taken by each car.

Which engine produces the most power?

	work done by engine / J	time taken / s
<b>A</b>	50 000	20
<b>B</b>	50 000	40
<b>C</b>	100 000	20
<b>D</b>	100 000	40

31 The diagram shows a shaped glass tube filled with water.

When the water is heated at the point shown, the water begins to move round the tube.

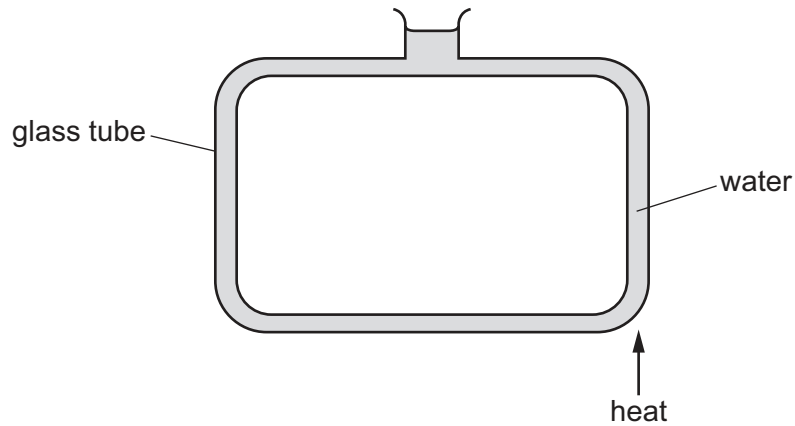

What is the main method of heat transfer that is occurring within the water and in which direction does the water move?

	method of heat transfer	direction of movement
<b>A</b>	conduction	anticlockwise
<b>B</b>	conduction	clockwise
<b>C</b>	convection	anticlockwise
<b>D</b>	convection	clockwise

32 A substance is a gas when its temperature is  $65^{\circ}\text{C}$ .

How do the boiling point and the melting point of this substance compare with  $65^{\circ}\text{C}$ ?

	boiling point	melting point
<b>A</b>	above $65^{\circ}\text{C}$	above $65^{\circ}\text{C}$
<b>B</b>	above $65^{\circ}\text{C}$	below $65^{\circ}\text{C}$
<b>C</b>	below $65^{\circ}\text{C}$	above $65^{\circ}\text{C}$
<b>D</b>	below $65^{\circ}\text{C}$	below $65^{\circ}\text{C}$

33 Light passes through a glass block that has parallel sides.

Which diagram shows the path of the light?

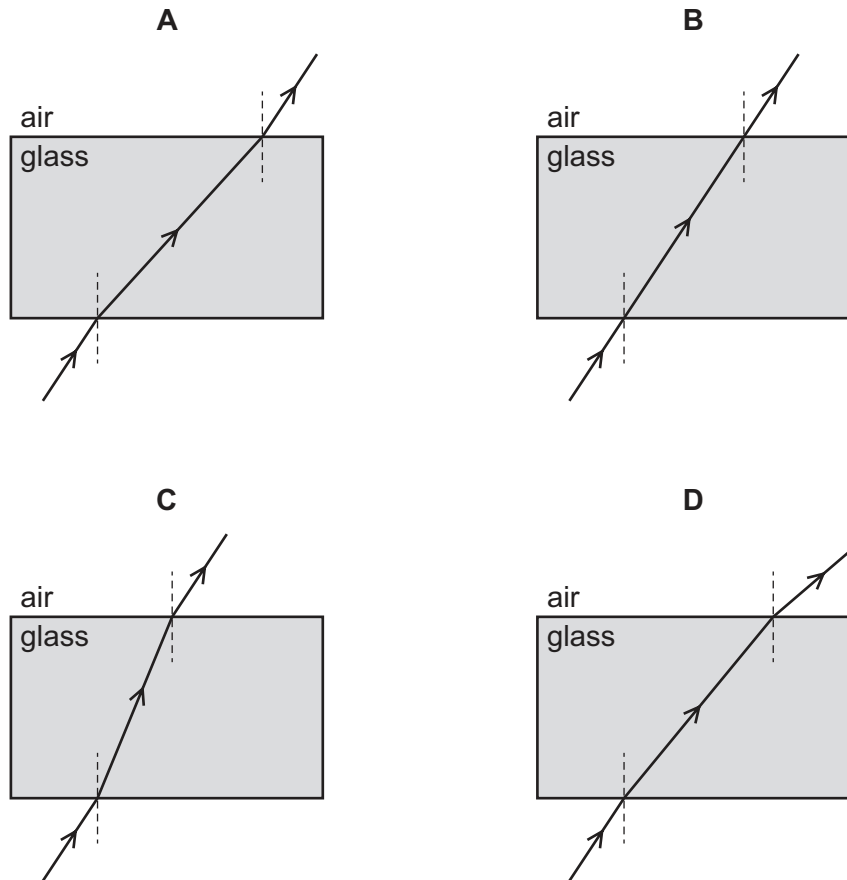

34 Which electromagnetic waves are used by television remote controllers?

- A gamma
- B infra-red
- C microwaves
- D X-rays

- 35 The diagram shows a circuit containing two switches P and Q, and three lamps. One lamp is labelled X.

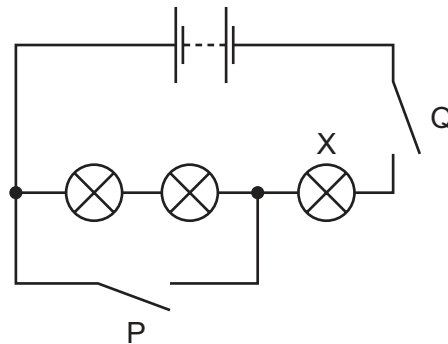

Which of the switches must be closed so that **only** lamp X is lit?

- A neither switch  
 B switch P only  
 C switch Q only  
 D switch P and switch Q
- 36 Which row shows how lamps are connected in a lighting circuit in a house and gives an advantage of connecting them in this way?

	how lamps are connected	advantage of connecting them in this way
<b>A</b>	in parallel	they can be switched separately
<b>B</b>	in parallel	they share the voltage
<b>C</b>	in series	they can be switched separately
<b>D</b>	in series	they share the voltage

- 37 An electrical extension block has four sockets, a cable which can safely take a current of 6 A and a plug. It is protected by a fuse rated at 5 A.

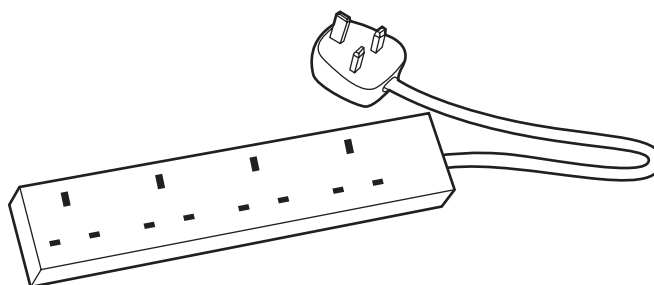

The extension block is used with four appliances and the 5 A fuse blows. The owner replaces the 5 A fuse with a 13 A fuse.

Why is the extension block now dangerous?

- A The appliances may overheat before the fuse blows.
  - B The cable may overheat before the fuse blows.
  - C The sockets may burn out before the fuse blows.
  - D The 13 A fuse may blow too soon.
- 38 There is a current-carrying wire perpendicular to the page.

The direction of the current is into the page.

Which diagram shows the pattern and direction of the magnetic field around the wire?

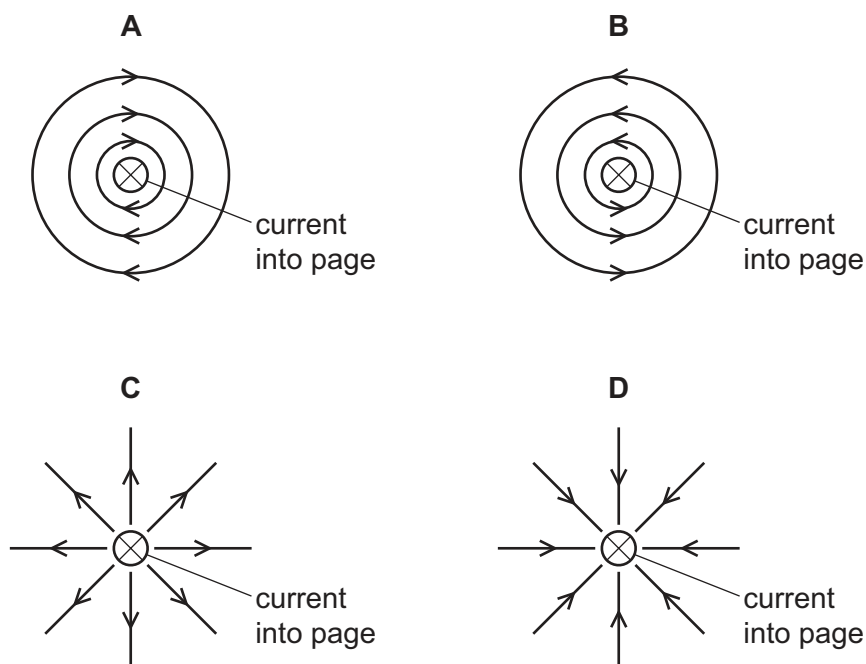

39 What is the proton number (atomic number) of the nuclide  $^{14}_6\text{C}$ ?

A 6

B 8

C 14

D 20

40 Which type of radiation has the greatest ionising effect, and which is the most penetrating?

	greatest ionising effect	most penetrating
<b>A</b>	$\alpha$ -particles	$\alpha$ -particles
<b>B</b>	$\alpha$ -particles	$\gamma$ -rays
<b>C</b>	$\gamma$ -rays	$\alpha$ -particles
<b>D</b>	$\gamma$ -rays	$\gamma$ -rays







**BLANK PAGE**

---

Permission to reproduce items where third-party owned material protected by copyright is included has been sought and cleared where possible. Every reasonable effort has been made by the publisher (UCLES) to trace copyright holders, but if any items requiring clearance have unwittingly been included, the publisher will be pleased to make amends at the earliest possible opportunity.

To avoid the issue of disclosure of answer-related information to candidates, all copyright acknowledgements are reproduced online in the Cambridge Assessment International Education Copyright Acknowledgements Booklet. This is produced for each series of examinations and is freely available to download at [www.cambridgeinternational.org](http://www.cambridgeinternational.org) after the live examination series.

Cambridge Assessment International Education is part of the Cambridge Assessment Group. Cambridge Assessment is the brand name of the University of Cambridge Local Examinations Syndicate (UCLES), which itself is a department of the University of Cambridge.

The Periodic Table of Elements

		Group															
I	II	III	IV	V	VI	VII	VIII					VIII					
3 Li lithium 7	4 Be beryllium 9	11 Na sodium 23	12 Mg magnesium 24	<div style="border: 1px solid black; padding: 5px; margin-bottom: 5px;"> <b>Key</b>                      atomic number                      atomic symbol                      name                      relative atomic mass                 </div>										2 He helium 4			
19 K potassium 39	20 Ca calcium 40	21 Sc scandium 45	22 Ti titanium 48	23 V vanadium 51	24 Cr chromium 52	25 Mn manganese 55	26 Fe iron 56	27 Co cobalt 59	28 Ni nickel 59	29 Cu copper 64	30 Zn zinc 65	31 Ga gallium 70	32 Ge germanium 73	33 As arsenic 75	34 Se selenium 79	35 Br bromine 80	36 Kr krypton 84
37 Rb rubidium 85	38 Sr strontium 88	39 Y yttrium 89	40 Zr zirconium 91	41 Nb niobium 93	42 Mo molybdenum 96	43 Tc technetium —	44 Ru ruthenium 101	45 Rh rhodium 103	46 Pd palladium 106	47 Ag silver 108	48 Cd cadmium 112	49 In indium 115	50 Sn tin 119	51 Sb antimony 122	52 Te tellurium 128	53 I iodine 127	54 Xe xenon 131
55 Cs caesium 133	56 Ba barium 137	57–71 lanthanoids	72 Hf hafnium 178	73 Ta tantalum 181	74 W tungsten 184	75 Re rhenium 186	76 Os osmium 190	77 Ir iridium 192	78 Pt platinum 195	79 Au gold 197	80 Hg mercury 201	81 Tl thallium 204	82 Pb lead 207	83 Bi bismuth 209	84 Po polonium —	85 At astatine —	86 Rn radon —
87 Fr francium —	88 Ra radium —	89–103 actinoids	104 Rf rutherfordium —	105 Db dubnium —	106 Sg seaborgium —	107 Bh bohrium —	108 Hs hassium —	109 Mt meitnerium —	110 Ds darmstadtium —	111 Rg roentgenium —	112 Cn copernicium —	114 Fl flerovium —	116 Lv livermorium —	118 Og oganeson —	119 Uue unbinilium —	120 Uub ununilium —	121 Uut unununium —

lanthanoids	57 La lanthanum 139	58 Ce cerium 140	59 Pr praseodymium 141	60 Nd neodymium 144	61 Pm promethium —	62 Sm samarium 150	63 Eu europium 152	64 Gd gadolinium 157	65 Tb terbium 159	66 Dy dysprosium 163	67 Ho holmium 165	68 Er erbium 167	69 Tm thulium 169	70 Yb ytterbium 173	71 Lu lutetium 175
actinoids	89 Ac actinium —	90 Th thorium 232	91 Pa protactinium 231	92 U uranium 238	93 Np neptunium —	94 Pu plutonium —	95 Am americium —	96 Cm curium —	97 Bk berkelium —	98 Cf californium —	99 Es einsteinium —	100 Fm fermium —	101 Md mendelevium —	102 No nobelium —	103 Lr lawrencium —

The volume of one mole of any gas is 24 dm<sup>3</sup> at room temperature and pressure (r.t.p.).